



High-Performance Cutters and Inserts

Mini-Feed



Mid-Feed



Heavy-Feed



DAPRA[®]

DAPRA CORPORATION
www.dapra.com

How Does **RHINO-FEED™** Work?

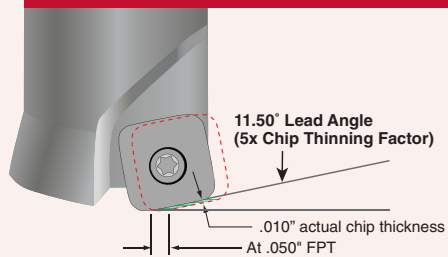

High-feed milling creates significant chip thinning due to an extreme lead angle. Feed rates must compensate for this to maximize productivity. The figure at left shows an example of this condition. Adjusting feed rates to account for chip thinning creates cutting conditions that provide very high feeds (IPM), but at lighter depths of cut (DOC). See the specific instructions for each size of high-feed insert below to get the most of your Dapra RHINO-FEED™ product!

RHINO-FEED™ Options:

R2 Mini-Feed Cutters and Inserts

p. 4-5

- .500" - 1.000" OD
- 8mm IC
- 3 usable edges
- .030" max. DOC



R3 Mid-Feed Cutters and Inserts

p. 6-7

- 1.000" - 2.000" OD
- 10mm IC
- 4 usable edges
- "T" or "D" cutting edge
- .045" max. DOC



R4 Heavy-Feed Cutters and Inserts

p. 8-9

- 1.25" - 4.00" OD
- 12mm IC
- 4 usable edges
- "T" or "D" cutting edge
- .060" max. DOC
- Extra-strong top clamping



What is ?

The ultra-aggressive geometry of RHINO-FEED, DAPRA's High-Feed line, takes advantage of chip thinning to allow feed rates up to 5x faster than normal!

Use RHINO-FEED high-feed inserts for:

- Mold cavity and core roughing
- Roughing of complex part contours
- Slotting
- 2D contouring
- Pocketing
- Helical interpolation
- Face milling
- Step milling

NOTE: High-feed milling does a tremendous amount of work in a short period of time. This line's high production rate can create more heat than typical milling tools. Strong air blast is recommended (multiple lines if possible).

High-Feed Cutter Bodies

- Through-hardened, extra-tough tool steel for optimum strength
- Surface hardened for extra wear and chip-welding resistance
- Machined after hardening for excellent runout
- Standard and long-reach bodies available

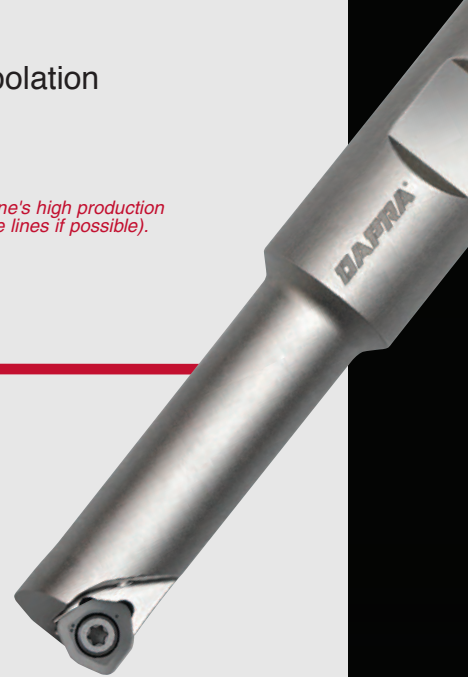

High-Feed Inserts

- Strong design allows high feed rates in all materials
- Positive clearance provides excellent ramping and helixing capabilities
- Multiple geometries for either smooth cutting or strong edge conditions
- Simple but effective grade variety provides strong performance in all materials



Index

Cutter Bodies and Inserts	4-9	Application Information	11
Modular Heads	4, 6	Hole Diameter Calculation	12
Modular Extensions	10	Insert Grades	13
Spare Parts and Tools	11	Recommended Cutting Speeds	14

R2: Mini-Feed Bodies

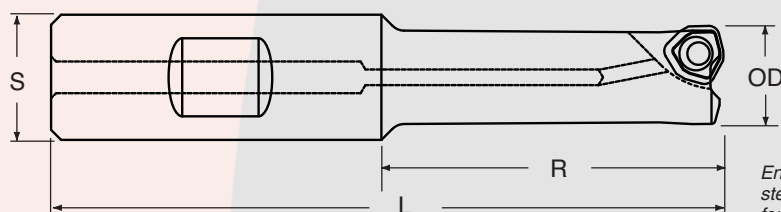

End Mills are solid steel, manufactured for coolant thru tool.

End Mills R2 – 8mm IC

OD Diameter	Holder	R Effective Length	L Overall Length	S Shank Dia.	Flutes	DOC Recommended	Insert
.500"	HFEM050-150-R2-1	1.500"	3.530"	.750"	1	.010-.015"	RF08
.500"	HFEM050-250-R2-1	2.500"	4.530"	.750"	1	.010-.015"	RF08
.625"	HFEM063-200-R2-1	2.000"	4.030"	.750"	1	.010-.025"	RF08
.625"	HFEM063-300-R2-1	3.000"	5.030"	.750"	1	.010-.020"	RF08
.750"	HFEM075-200-R2-2	2.000"	4.030"	.750"	2	.010-.025"	RF08
.750"	HFEM075-300-R2-2	3.000"	5.030"	.750"	2	.010-.020"	RF08
1.000"	HFEM100-250-R2-3	2.500"	4.750"	1.000"	3	.010-.025"	RF08
1.000"	HFEM100-450-R2-3	4.500"	6.750"	1.000"	3	.010-.025"	RF08

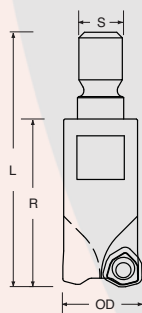

Modular Heads are solid steel, not thru-coolant equipped.

Modular Heads R2 – 8mm IC

OD Diameter	Holder	R Effective Length	L Overall Length	S Shank Dia.	Flutes	Thread	DOC Recommended	Insert
.750"	HFEM075-MOD-R2-2	1.500"	2.275"	0.413"	2	M10	.010-.020"	RF08
1.000"	HFEM100-MOD-R2-3	1.500"	2.375"	0.492"	3	M12	.010-.020"	RF08

Mini-Feed Inserts

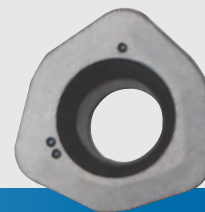

Insert Part Number	IC	Thick-ness	# of Usable Edges	Corner Radius (Actual)	Corner Radius (Program)	DOC (Max.)	DOC (Recommended)	FPT (Compensated)
RF08-D	8MM	.125"	3	.062"	.088"	.030"	.010-.025"	.012-.032"

* A special corner radius value is required for correct programming of a high-feed insert. Using the program radius avoids gouging of the corners in the workpiece material.

The high-feed insert will naturally leave a small amount of extra material at the bottom-most layer of the cut, at the intersection of the wall and pocket floor. (See diagram at the bottom of this page.)

RHINO-FEED inserts are labeled with dots to indicate die position during pressing. For the most accurate runout when loaded into the cutter body, make sure each insert is loaded with the corresponding edge.



"D" inserts have a positive cutting geometry, designed to reduce cutting forces and heat. This edge is suitable for all materials.

Mini-Feed RF08 Grade Availability

See page 13 for grade descriptions.

Uncoated	with Coating	
DMK30 D	DMK30-HP D	DMK30-GLH D
DMK25 D	DMK25-HP D	DMK25-GLH D
DMP25 D	DMP25-HP D	DMP25-GLH D

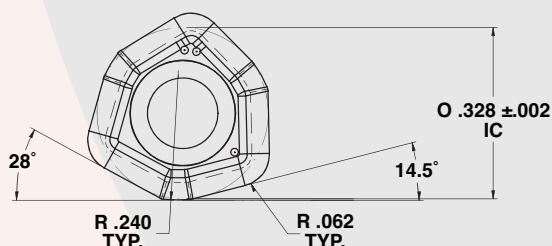
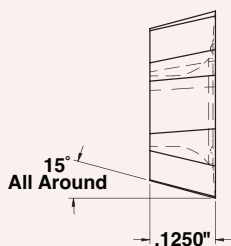

Operating Instructions for Mini-Feed Inserts



Mini-feed inserts have the smallest IC (inscribed circle) and smallest cross section. It is suggested to run a good common-sense combination of feed and DOC with these inserts. When running a light DOC, the higher end of the feed range is acceptable. When running heavier DOC, use the lower to middle feed ranges. Index inserts promptly upon visible wear to avoid breakage.

If cutting at .025" DOC and trying for a .007" chip thickness, multiply .007" x 4 = .028" FPT.

Prog R .088" 0.030" Max. DOC

Compensated FPT (from chart above):

Dapra's mini-feed inserts have a 4x chip thinning factor. The compensated FPT recommendation of .012-.032" represents an actual chip thickness of .003-.008".

R3: Mid-Feed Bodies

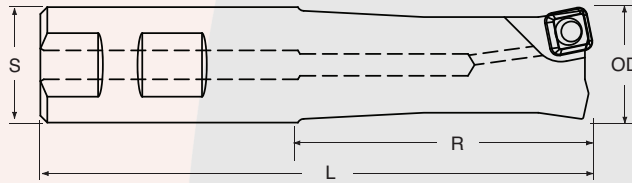

End Mills are solid steel, manufactured for coolant thru tool.

End Mills R3 –10mm IC

OD Diameter	Holder	R Effective Length	L Overall Length	S Shank Dia.	Flutes	DOC Recommended	Insert
1.000"	HFEM100-250-R3-2	2.500"	4.750"	1.000"	2	.015-.040"	RF10
1.000"	HFEM100-450-R3-2	4.500"	6.750"	1.000"	2	.015-.030"	RF10
1.250"	HFEM125-300-R3-3	3.000"	5.280"	1.250"	3	.015-.040"	RF10
1.250"	HFEM125-500-R3-3	5.000"	7.280"	1.250"	3	.015-.030"	RF10
1.500"	HFEM150-350-R3-3	3.500"	5.780"	1.250"	3	.015-.040"	RF10
1.500"	HFEM150-550-R3-3	5.500"	7.780"	1.250"	3	.015-.030"	RF10

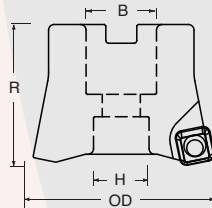

Shell Mills are solid steel, not thru-coolant equipped.

Shell Mills R3 – 10mm IC

OD Diameter	Holder	R Effective Length	B Arbor Dia.	H Counter Bore Dia.	Flutes	DOC Recommended	Insert
2.000"	HFEM200-075-R3-5	1.500"	.750"	0.590"	5	.015-.040"	RF10

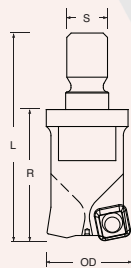

Modular Heads are solid steel, not thru-coolant equipped.

Modular Heads R3 –10mm IC

OD Diameter	Holder	R Effective Length	L Overall Length	S Shank Dia.	Flutes	Thread	DOC Recommended	Insert
1.000"	HFEM100-MOD-R3-2	1.500"	2.375"	.492"	2	M12	.015-.030"	RF10
1.250"	HFEM125-MOD-R3-3	1.750"	2.750"	.669"	3	M16	.015-.030"	RF10
1.500"	HFEM150-MOD-R3-3	1.750"	2.750"	.669"	3	M16	.015-.030"	RF10

Mid-Feed Inserts

"T" inserts have a reinforced cutting edge for steels, irons and hard milling

"D" inserts have a positive cutting geometry, designed to reduce cutting forces and heat. This edge is suitable for all materials.



Insert Part Number	IC	Thickness	# of Usable Edges	Corner Radius (Actual)	Corner Radius (Program)	DOC (Max.)	DOC (Recommended)	FPT (Compensated)
RF10-T	10MM	.190"	4	.075"	.105"	.045"	.015-.040"	.020-.060"
RF10-D	10MM	.190"	4	.075"	.105"	.045"	.015-.040"	.015-.050"

* A special corner radius value is required for correct programming of a high-feed insert. Using the program radius avoids gouging of the corners in the workpiece material.

The high-feed insert will naturally leave a small amount of extra material at the bottom-most layer of the cut, at the intersection of the wall and pocket floor. (See diagram at bottom of this page.)

RHINO-FEED inserts are labeled with dots to indicate die position during pressing. For the most accurate runout when loaded into the cutter body, make sure each insert is loaded with the corresponding edge.

Mid-Feed RF10 Grade Availability

See page 13 for grade descriptions.

Uncoated	with Coating	
DMK30 T, D	DMK30-HP T, D	DMK30-GLH T, D
DMK25 D	DMK25-HP D	DMK25-GLH D
DMP25 T, D	DMP25-HP T, D	DMP25-GLH T, D

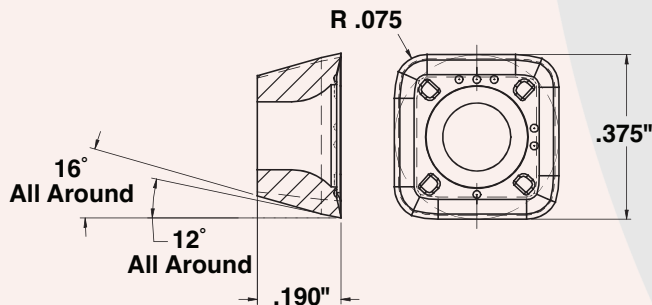

Operating Instructions for Mid-Feed Inserts

Mid-feed inserts have a stronger cross-section than the mini-feed, but are smaller than the heavy-feed. These are great general-purpose inserts best suited for lighter-duty (40-taper, linear ways, etc.) machines. Run faster feeds with lighter DOC in most situations. In heavier DOC, run the lower to middle area of the feed ranges.

If cutting at .030" DOC and trying for a .010" chip thickness, multiply .010" x 5 = .050" FPT.

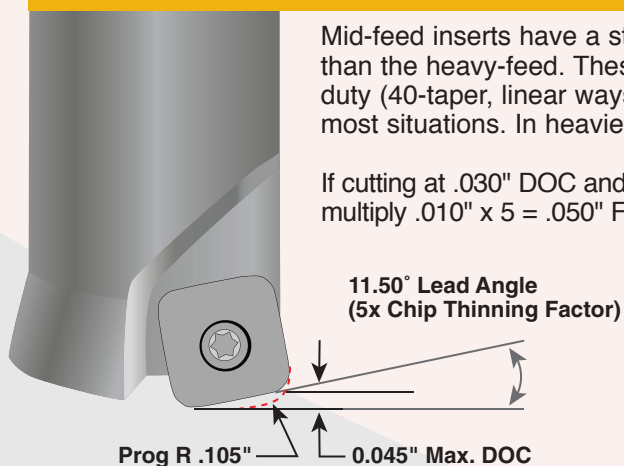

Compensated FPT (from chart above):

Dapra's mid-feed inserts have a 5x chip thinning factor. The compensated FPT recommendation of .020-.060" ("T") and .015-.050" ("D") represents an actual chip thickness of .004-.012" and .003-.010", respectively.

R4: Heavy-Feed Bodies

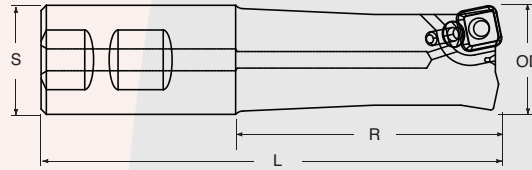

End Mills are solid steel, manufactured for coolant thru tool.

End Mills R4 – 12mm IC

OD Diameter	Holder	R Effective Length	L Overall Length	S Shank Dia.	Flutes	DOC Recommended	Insert
1.250"	HFEM125-300-R4-2	3.000"	5.280"	1.250"	2	.020-.050"	RF12
1.250"	HFEM125-500-R4-2	5.000"	7.280"	1.250"	2	.020-.040"	RF12
1.500"	HFEM150-350-R4-3	3.500"	5.780"	1.250"	3	.020-.050"	RF12
1.500"	HFEM150-550-R4-3	5.500"	7.780"	1.250"	3	.020-.040"	RF12

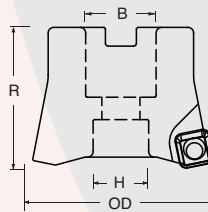

Shell Mills are solid steel, not thru-coolant equipped.

Shell Mills R4 – 12mm IC

OD Diameter	Holder	R Effective Length	B Arbor Dia.	H Counter Bore Dia.	Flutes	DOC Recommended	Insert
2.000"	HFSM200-075-R4-4	1.500"	.750"	.590"	4	.020-.050"	RF12
2.000"	HFSM200-075-R4-5	1.500"	.750"	.590"	5	.020-.050"	RF12
2.500"	HFSM250-100-R4-5	2.000"	1.000"	.790"	5	.020-.050"	RF12
3.000"	HFSM300-100-R4-6	2.000"	1.000"	.790"	6	.020-.050"	RF12
4.000"	HFSM400-150-R4-8	2.000"	1.500"	2.060"	8	.020-.050"	RF12

Heavy-Feed Inserts

"T" inserts have a reinforced cutting edge for steels, irons and hard milling

"D" inserts have a positive cutting geometry, designed to reduce cutting forces and heat. This edge is suitable for all materials.

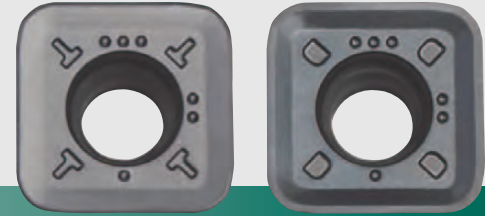

Insert Part Number	IC	Thickness	# of Usable Edges	Corner Radius (Actual)	Corner Radius (Program)	DOC (Max.)	DOC (Recommended)	FPT (Compensated)
RF12-T	12MM	.220"	4	.094"	.135"	.060"	.020-.050"	.025-.070"
RF12-D	12MM	.220"	4	.094"	.135"	.060"	.020-.050"	.020-.055"

* A special corner radius value is required for correct programming of a high-feed insert. Using the program radius avoids gouging of the corners in the workpiece material.

The high-feed insert will naturally leave a small amount of extra material at the bottom-most layer of the cut, at the intersection of the wall and pocket floor. (See diagram at the bottom of this page.)

RHINO-FEED inserts are labeled with dots to indicate die position during pressing. For the most accurate runout when loaded into the cutter body, make sure each insert is loaded with the corresponding edge.

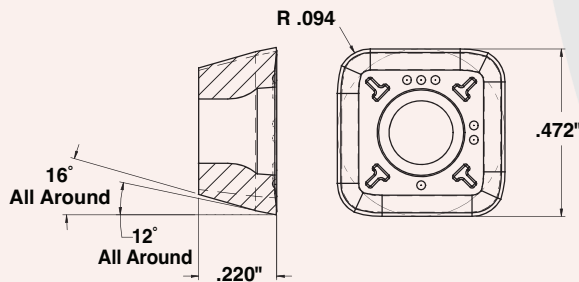

Heavy-Feed RF12 Grade Availability

See page 13 for grade descriptions.

Uncoated	with Coating	
DMK30 T, D	DMK30-HP T, D	DMK30-GLH T, D
DMP25 T, D	DMP25-HP T, D	DMP25-GLH T, D

Operating Instructions for Heavy-Feed Inserts

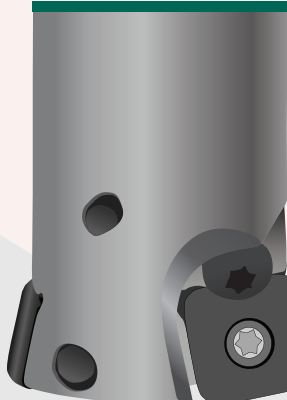

Heavy-feed inserts have the strongest cross-section of the RHINO-FEED line. With their additional top-clamping, heavy-feed inserts are suitable for heavier DOC and larger machines (50 taper, box ways, etc). For optimum performance, use good combinations of heavier DOC with light-to-middle FPT, or lighter DOC with heavier FPT.

If cutting at .030" DOC and trying for a .010" chip thickness, multiply .010" x 5 = .050" FPT.

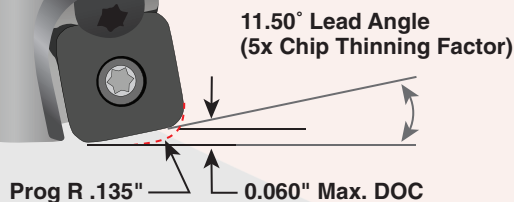

Compensated FPT (from chart above): Dapra's heavy-feed inserts have a 5x chip thinning factor. The compensated FPT recommendation of .025-.070" ("T") and .020-.055" ("D") represents an actual chip thickness of .005-.014" and .004-.011", respectively.

Carbide Core Modular Extensions

Dapra's Carbide Core Modular Extensions Are Ideal for Standard Inch End Mill Holders

- Standard inch shanks, providing adaptation for end mill holders, milling chucks and heat-shrink holders
- 3 sizes to accommodate modular head sizes from 3/4" to 1 1/2"
- Carbide core for enhanced vibration dampening capability, reduced deflection and improved rigidity
- Optional add-on extensions for additional 2" reach – screw on to base extensions (for 3/4" to 1 1/2" modular heads)



Carbide Core Modular Extensions

For Head Dia.	Extension Part No.	Shank Dia.	Effective Length	OAL	Thread	CC	A
.750"/20mm	CC-ME-0750-3500-WOF	1.000"	3.7"	6.0"	M10	7/16" x 4.0"	.660
1.000"/25mm	CC-ME-1000-4500-WOF	1.000"	4.7"	7.0"	M12	7/16" x 5.0"	.935
1.250"/1.500"	CC-ME-1250-5500-WOF	1.250"	5.7"	8.0"	M16	1/2" x 6.0"	1.175

Extensions feature a cylindrical shank, with no Weldon flats. Hold with high-performance milling chucks or heat/mechanical shrink holders, or mill Weldon flats and use a short-length solid end mill holder.

2" Add-On Extensions

For Head Dia.	Extension Part No.	Effective Length	Thread
.750"/20mm	ME-0750-2" EXTENSION ADAPTER	2.0"	M10
1.000"/25mm	ME-1000-2" EXTENSION ADAPTER	2.0"	M12
1.250"/1.500"	ME-1250-2" EXTENSION ADAPTER	2.0"	M16

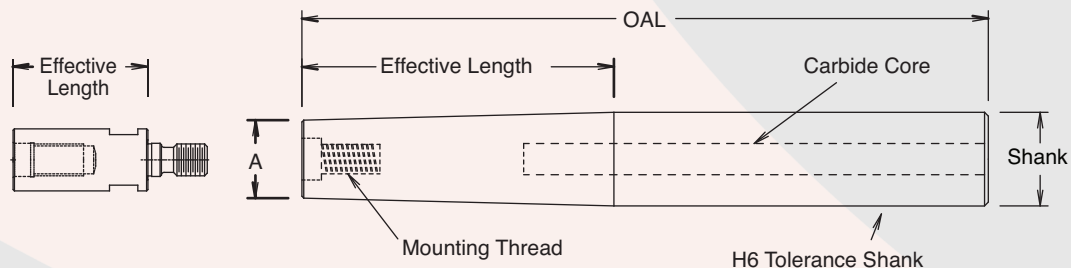

Visit www.dapra.com for additional Modular Extensions.

Recommendations

- Tool is most appropriate for "Z-level" roughing; ramp to Depth of Cut (DOC) and clear entire level.
- Plunging is not recommended with RHINO-FEED inserts. Ramping (up to 2° max.) is recommended.
- Climb milling is absolutely required with RHINO-FEED tooling. Cutter or part damage can occur with extended conventional milling.
- Try to maintain at least 75% of the cutter diameter on the workpiece whenever possible. Hanging a cutter off to the side of your work is detrimental to tool life and performance.
- Width of Cut (WOC) should be 60-75% of cutter diameter whenever possible. A slight scalloping effect between passes is acceptable. For longer-reach tools, this is especially important – cutting pressure should be on both sides of the center line.
- High-feed milling produces a thick chip that is efficient at carrying away heat. Combine this with running a slightly lower SFM than normal to get very good tool life.
- Use the Feed Rate Compensation charts on each insert page to compensate for chip thinning that occurs with RHINO-FEED inserts. This will provide for optimum metal removal rates and tool life.

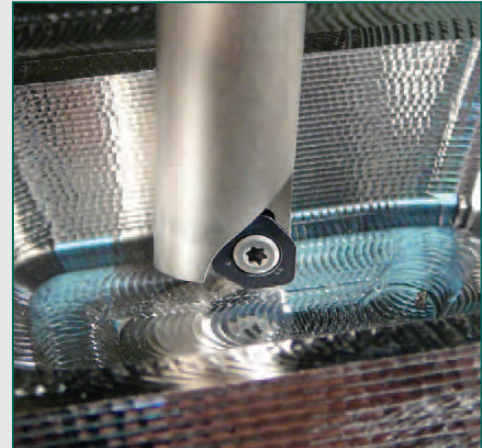

Technical Considerations

- Always use anti-seize compound on screws.
- Change insert screw every 10 inserts.
- Use the shortest-length tool holder (end mill holder) for maximum rigidity; the shank of the cutting tool should be up inside the machine spindle taper whenever possible.
- Thoroughly clean pocket and screw at each insert change.
- Use tool holders appropriate for roughing operations: end mill holders and power chucks *are* recommended; collets *are not* recommended.

Safety

Modern metal cutting techniques involve the potential use of very high operating parameters (speeds, feeds, depths of cut, etc.). This creates the potential for flying chips and debris, and can also create tool breakage due to a variety of causes. As such, any metal cutting operation should be executed in a completely enclosed (shielded) environment to protect against injury from flying objects. Dapra does not assume responsibility for any loss, damage or expense incurred in any use or handling of our products after purchase.

Grinding produces hazardous dust. To avoid adverse health effects, use adequate ventilation and read material safety data sheet first.

Spare Parts & Tools



Mini-Feed R2	Mid-Feed R3	Heavy-Feed R4
Spare Parts & Tools		
Insert Screw: TRS-3 Torque: 12-15 in-lbs Wrench: T-8F	Insert Screw: SSTX15-S Torque: 30-35 in-lbs Wrench: T-15F	Insert Screw: TRS-4L Torque: 30-35 in-lbs Clamp Screw: TRS-4CL Torque: 12-15 in-lbs Wrench: T-15F

All listed tools use Anti-Seize Grease ASG-120

New cutter bodies may require additional torque to fully seat the inserts. Once the new cutter's pockets are "broken in," the recommended torque specs in the chart can be followed regularly.

Hole Diameter Calculation

Helical Interpolation for Larger Diameter Hole Making



Larger diameter hole making can be quick and easy when a RHINO-FEED Cutter is used in combination with helical interpolation. This technique resembles thread milling in that all three axes (X, Y and Z) are in motion simultaneously. It differs from thread milling in that the tool is introduced into the material without a start hole of any kind. The tool simply is positioned at the inside diameter of the hole to begin its helix from there, achieving complete material removal from the hole by ramping down to the final depth. This smooth operation tends to avoid the high horsepower consumption characteristic of large diameter hole making. This quick and easy process offers the added advantage of allowing many different hole sizes to be generated with the same diameter tool. Hole size variation is all in the programming.

For more information on how helical interpolation can improve your manufacturing efficiency, contact your Dapra Applications Specialist.

Mini-Feed (R2 – 8mm IC)

Holder	Minimum Hole Dia.
HFEM050-150-R2-1	.65"
HFEM050-250-R2-1	.65"
HFEM063-200-R2-1	.78"
HFEM063-300-R2-1	.78"
HFEM075-MOD-R2-2	1.09"
HFEM075-200-R2-2	1.09"
HFEM075-300-R2-2	1.09"
HFEM100-250-R2-3	1.58"
HFEM100-450-R2-3	1.58"
HFEM100-MOD-R2-3	1.58"

Mid-Feed (R3 – 10mm IC)

Holder	Minimum Hole Dia.
HFEM100-250-R3-2	1.375"
HFEM100-450-R3-2	1.375"
HFEM100-MOD-R3-2	1.375"
HFEM125-300-R3-3	1.875"
HFEM125-500-R3-3	1.875"
HFEM125-MOD-R3-3	1.875"
HFEM150-350-R3-3	2.375"
HFEM150-550-R3-3	2.375"
HFEM150-MOD-R3-3	2.375"
HFEM200-075-R3-5	3.375"

Heavy-Feed (R4 – 12mm IC)

Holder	Minimum Hole Dia.
HFEM125-300-R4-2	1.75"
HFEM125-500-R4-2	1.75"
HFEM150-350-R4-3	2.25"
HFEM150-550-R4-3	2.25"
HFEM200-075-R4-4	3.25"
HFEM200-075-R4-5	3.25"
HFEM250-100-R4-5	4.25"
HFEM300-100-R4-6	5.25"
HFEM400-150-R4-8	7.25"

Maximum Hole Dia.* = Tool Dia. x 2

** Not generally recommended. At this diameter, the center tip is at its maximum. It is suggested that you stay slightly under this number.*

Shock & Wear Resistance	Uncoated (Base Grade)	with Coating	Description	Specifications
TOUGHEST Shock Resistance	DMK30		Moderate wear resistance/high shock resistance. Recommended for interrupted or unstable steel, most 300 series stainless steel, high-temperature alloys and cast iron applications.	ANSI C1-C2 ISO K25-K40, M25-M35
		DMK30-HP	High-performance medium-temperature grade. Optimum performance and wear resistance in most soft steels, soft stainless steels and cast irons.	
		DMK30-GLH	Premium high-temperature coating. Best resistance to heat for high-shock applications. Excellent for tough stainless steels, high-temperature alloys and many tool steels.	
MEDIUM Shock and Wear	DMK25		Micro-grain carbide providing higher wear resistance and good shock resistance for applications in tough stainless steels, high-temperature alloys, irons and many tool steels.	ANSI C2-C3 ISO K15-K30 M15-M30
		DMK25-HP	High-performance medium-temperature grade. Optimum performance and wear resistance in most soft steels, soft stainless steels and cast irons.	
		DMK25-GLH	Premium high-temperature coating. Outstanding performance and wear resistance in high-heat applications involving tough stainless steels, high-temperature alloys and many tool steels.	
MEDIUM Shock and Wear	DMP25		High wear resistance/moderate shock resistance. Recommended for most steel and ductile iron applications.	ANSI C5-C6 ISO P25-P40
		DMP25-HP	High-performance medium-temperature grade. Optimum performance and wear resistance in most soft steels and cast irons.	
		DMP25-GLH	Premium high-temperature grade. Unbeatable performance and wear resistance in high-heat applications such as higher speed machining in steels (< 44 Rc) and ductile irons.	

DMK30-HP is a good first choice for most applications.
Additional coatings available on request. Contact Dapra for details.

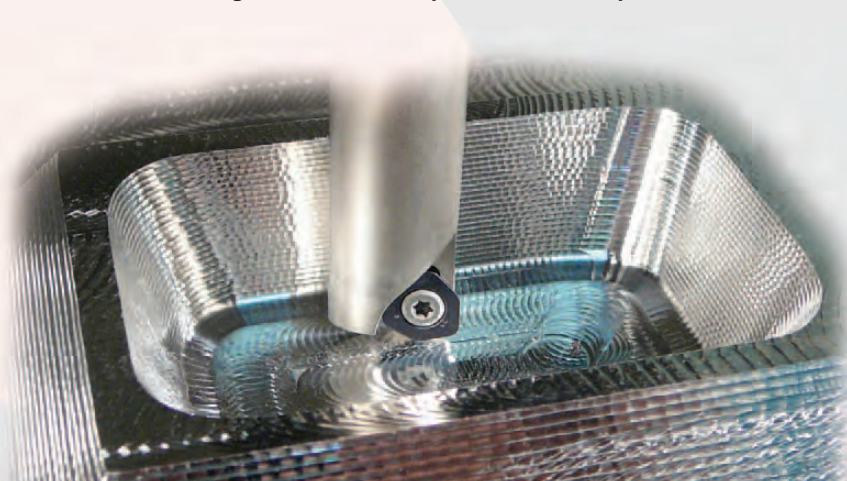

Recommended Cutting Speeds

Cutting Speeds for Dapra RHINO-FEED Cutters		1018, 12L14, 1041, 1045	4140, 4150 4340, H13, P20, A2, D2	4140, 4150 4340, H13, P20, A2, D2	303, 304 LOW 400 SERIES	316, 347, PH STAINLESS	GRAY, MALLEABLE, DUCTILE	6061, 7075	AMPCO, WEARITE	INCONEL, WASPALOY, MONEL		
		LOW-TO-MEDIUM CARBON STEELS	TOOL STEELS, HIGH-ALLOY STEELS (SOFT)	TOOL STEELS, HIGH-ALLOY STEELS (HARDENED)	FREE MACHINING STAINLESS	TOUGHER STAINLESS	CAST IRONS	ALUMINUM ALLOYS	COPPER ALLOYS	HIGH-TEMP. ALLOYS/TITANIUM	PLASTICS, NON-FERROUS	
TOUGHEST Shock Resistance	↑ LOWER TEMPS ↓ HIGHER TEMPS	DMK30-HP	350-550	300-500	NR	250-500	250-450	350-600	NR	300-800		NR
		DMK30-GLH	450-700	350-600	NR	300-600	250-500	400-750	NR		50-200	NR
MEDIUM Shock & Wear	↑ LOWER TEMPS ↓ HIGHER TEMPS	DMK25-HP	400-700	350-600	NR	300-600	250-550	300-650	NR			NR
		DMK25-GLH	450-800	400-700	200-500	300-700	250-600	300-750	NR		50-200	NR
MEDIUM Shock & Wear	↑ LOWER TEMPS ↓ HIGHER TEMPS	DMP25-HP	400-700	350-600	NR	300-600		300-650 DUCTILE	NR		NR	NR
		DMP25-GLH	450-800	400-700	200-500	300-700		300-750 DUCTILE	NR		NR	NR
1 st CHOICE GEOMETRY		T	T	T	D	D	T	NR	D	D	NR	NR

NOTE: High-feed milling does a tremendous amount of work in a short period of time. This line's high production rate can create more heat than typical milling tools. Strong air blast is recommended (multiple lines if possible).

** Best choice for material shown in bold text

The parameters provided are suggested operating parameters. Actual speeds and feeds will depend on many variables, such as rigidity, workpiece hardness, tool extension, machine accuracy, Depth of Cut, etc. Start at the middle of the SFM range and the low end of the FPT range. Next, increase FPT to optimize productivity and tool life. Higher SFM will provide higher output but may reduce tool life. Try different combinations to find the parameters that best suit your needs.

- The -HP coatings are best suited for low to medium operating speeds (temperatures) and softer materials.
- The -GLH coatings are best suited for high operating speeds (temperatures) and harder materials.



Dapra High-Feed products are made in the USA.

DAPRA CORPORATION

Bringing Better Ideas to the Cutting Edge™

66 Granby Street, Bloomfield, CT 06002

800-243-3344 • 860-242-8539 • Fax 860-242-3017

Email info@dapra.com • www.dapra.com